

sales 1

De: sales 1
Enviado em: segunda-feira, 9 de outubro de 2023 12:26
Para: 'info@fasteners.eu'
Cc: Rui Aparecido; Sales2
Assunto: RFQ 39560/DV - STUD / NUT / WASHER / GUIDES / THREADED

Controle:	Destinatário	Ler
	'info@fasteners.eu'	
	Rui Aparecido	Lida: 09/10/2023 13:19
	Sales2	Lida: 09/10/2023 14:56

Dear Ladies & Gentlemen, have a nice day!

Could you please quote the items below?

ITEM	DESCRIPTION	QTY.	GERMANY MATERIAL	USA MATERIAL
2	LOWER COMPENSATION STUD	20 units	S355J2H	ASTM A 193 Gr.B7 / ASTM A 193 Gr.B16 or equivalent
3	SHORT COMPENSATION STUD	20 units	S355J2H	ASTM A 193 Gr.B7 / ASTM A 193 Gr.B16 or equivalent
6	THREADED COVER	20 units	1.4833	AISI 309S / AISI 310S
17	HEXAGON NUT	80 units	DIN 934	DIN 934 similar or equivalent
19	SPHERICAL WASHER C21	20 units	DIN 6319	DIN 6319 similar or equivalent
20	SPHERICAL WASHER D28	20 units	DIN 6319	DIN 6319 similar or equivalent
17	HEXAGON NUT	80 units	DIN 934	DIN 934 similar or equivalent
-	WASHER	40 units	DIN 125	DIN 125 similar or equivalent
19	SPHERICAL WASHER C21	20 units	DIN 6319	DIN 6319 similar or equivalent
20	SPHERICAL WASHER D 28	20 units	DIN 6319	DIN 6319 similar or equivalent
6	GUIDE BUSH	20 units	C45	SAE 1045
10	GUIDE WASHER	20 units	C45	SAE 1045

ITEM	UNIT	DESCRIPTION	MATERIAL	UNIT WEIGHT	TOTAL WEIGHT
2	1	LOWER COMPENSATION STUD	S355J2H	1.87	1.87

12.5 / 

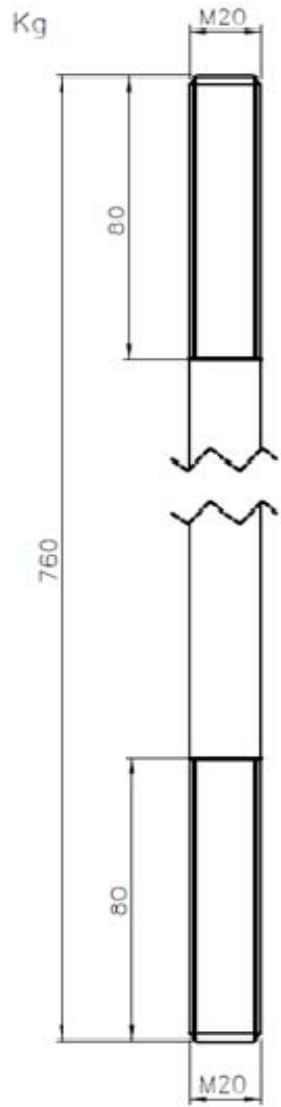

ITEM	UNIT	DESCRIPTION	MATERIAL	UNIT WEIGHT	TOTAL WEIGHT
3	1	SHORT COMPENSATION STUD	S355J2H	0.61	0.61

12.5 /
▽

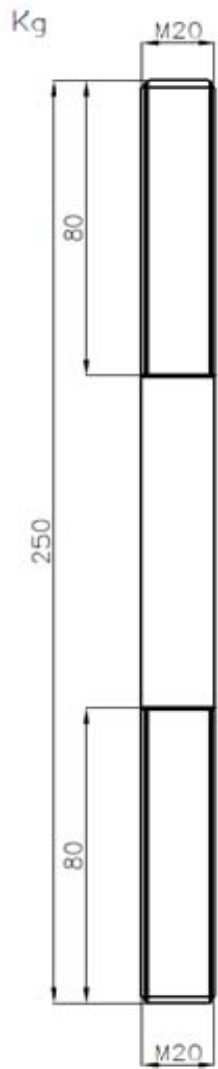

ITEM	UNIT	DESCRIPTION	MATERIAL	UNIT WEIGHT	TOTAL WEIGHT
6	1	THREADED COVER	1.4833	1.367	1.367

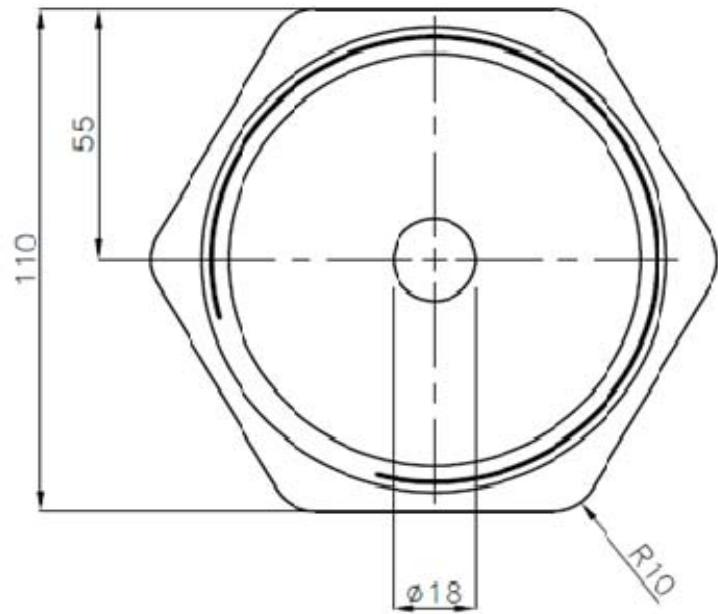
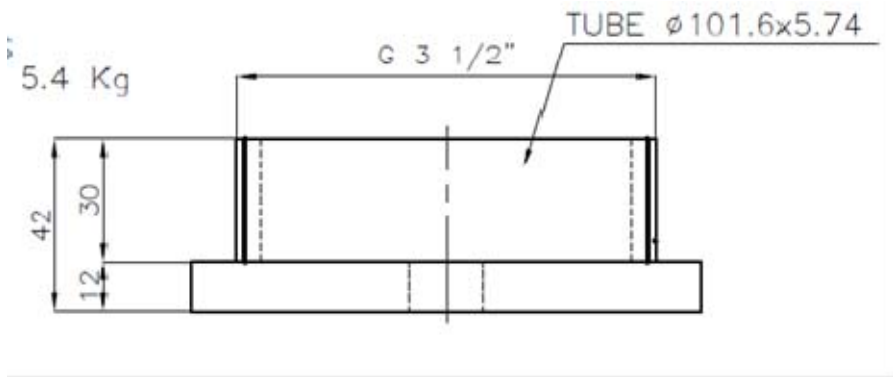

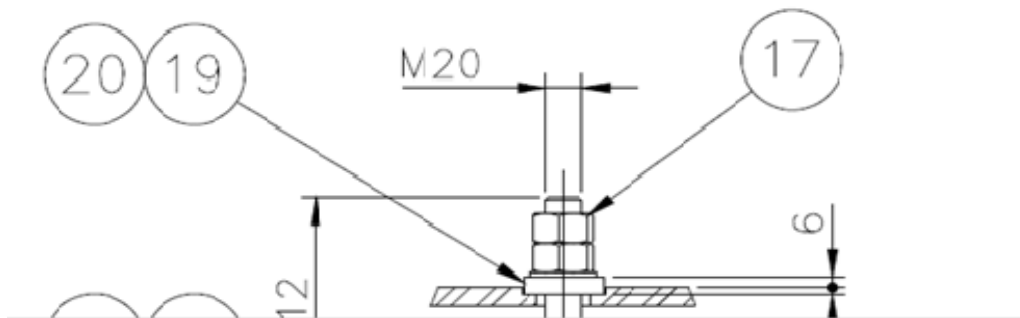

17	16	HEXAGON NUT M 20.00 DIN 934 (ISO 4032)	8	-	0.000	0
20	8	SPHERICAL WASHER D28 DIN 6319	St.	-	0.06	0.48
19	8	SPHERICAL WASHER C21 DIN 6319	St.	-	0.02	0.16

WASHER A21 DIN 125 (ISO7090)-St.

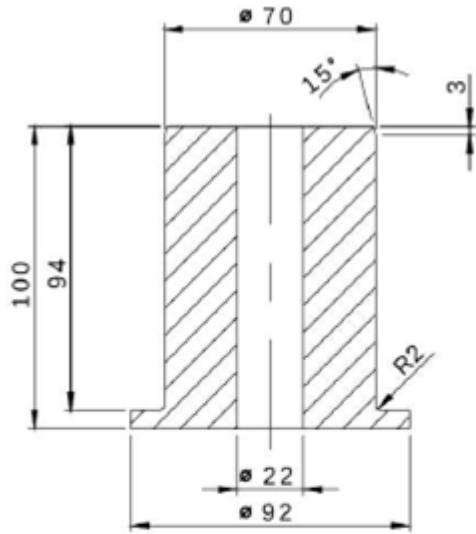

6 GUIDE BUSH 12.5
 MATERIAL: C45
 WEIGHT: 2.85 Kgs.
 SCALE: 1:2

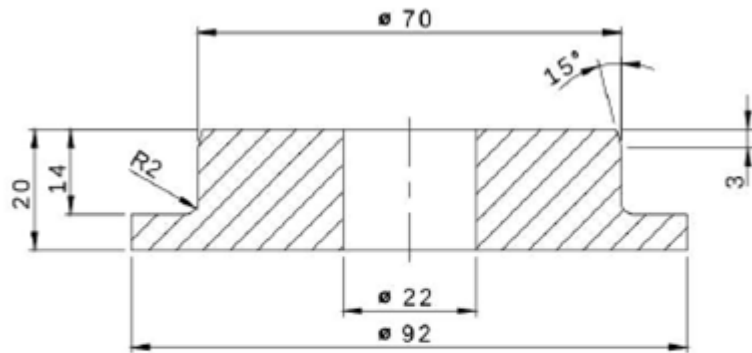

10 GUIDE WASHER
 MATERIAL: C45
 WEIGHT: 0.68 Kgs.
 SCALE: 1:1

Included in your proposal:

- Mill test certificates and reports.
- Export packaging according to manufacturer's standard.

Note: *supply of this technical documentation applicable only after the submission of a purchase order by the JUNIOR FLEX Company.*

We need your commercial proposal as soon as possible.

Any questions about this quote request, please don't hesitate to contact me.

Thanks in advance for your understanding.

Sincerely and looking forward to your quick reply.

André Franqueira
Technical Estimator
Commercial Department
Tel: +55 11 4136-4525

