

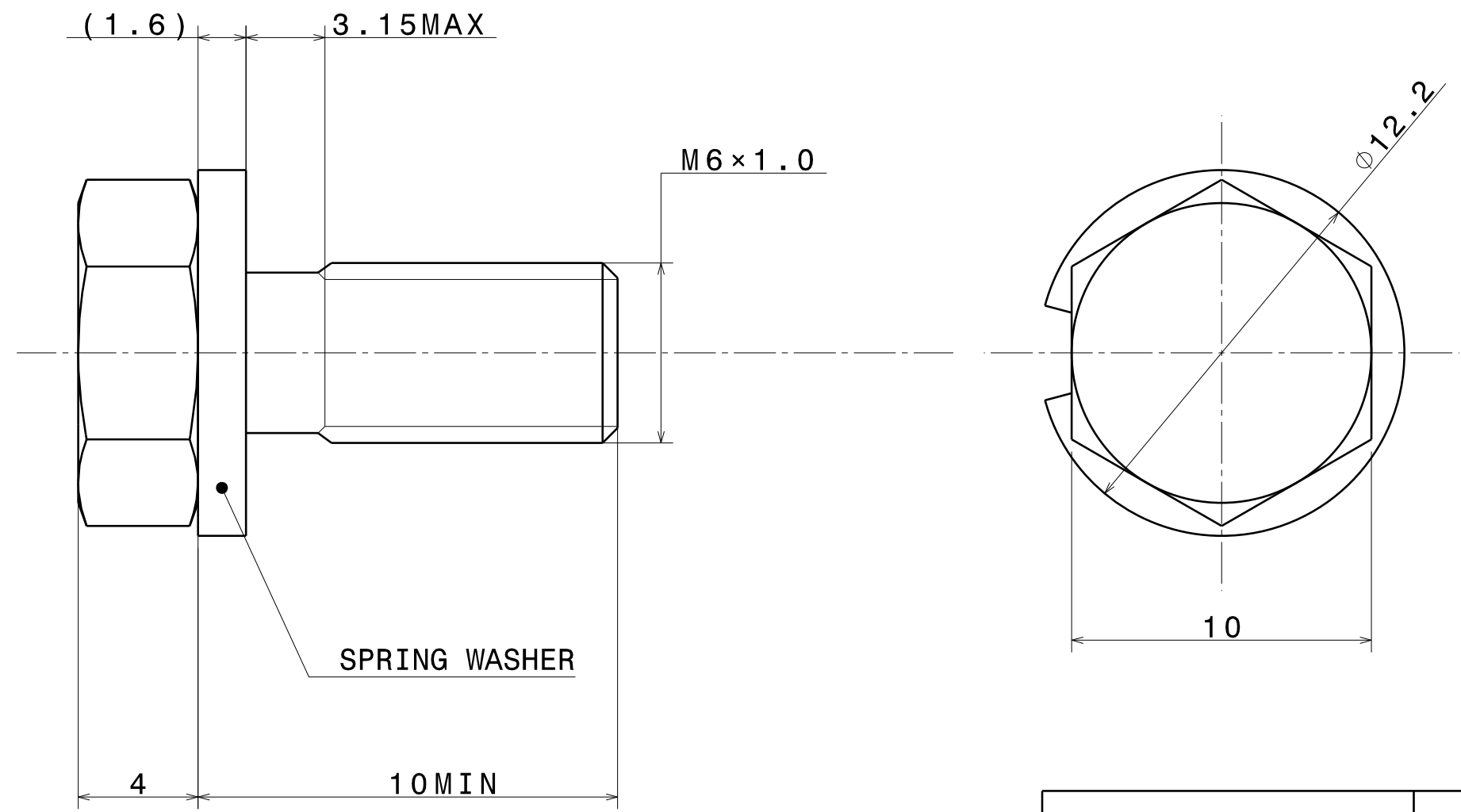

A B C D E F G H I J K L M N O P

NOTE
 1- Bolt strength crass : 4.8(TBD)
 7- No crack, no fissure, no material tear-off admitted.
 8- No rust admitted at delivery condition
 11-Recycling: according to european directive 2000/53/EC

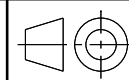

ASSY		15.0g	-----	-----
MATERIAL		WEIGHT	TREATMENT	PROTECTION
TOLERANCE PRINCIPLE ISO 5459 ISO 8015 ISO 1101	GENERAL TOLERANCES Cut ISO 2768-1 classe m Other dimension ISO 2768-1 classe c	GEOMETRICAL GENERAL TOLERANCES	SURFACE FINISH ISO 2768-2 classe K ISO 1302	
DRAWN BY	NAME: URUMA	DATE: 28/8/18		 Autotec FUJI AUTOTECH FRANCE 1815629
VIS DE REGLAGE <hr/> BOLT WITH WASHER			A	
CREATED FOR	DESIGN NOTE	This drawing is property of Fuji Autotech France. It cannot be modified, copied or transmitted without his authorization		
URUMA	28/8/18	CMF - B	K0266 - 022	 SCALE 5/1 A3 1/1

A B C D E F G H I J K L M N O P