

Babcock & Wilcox Power Generation Group, Inc.
 20 SOUTH VAN BUREN AVENUE, BARBERTON, OHIO

REVISIONS

| REV | DESCRIPTION | DATE | APPROVAL | * |
|-----|--|----------|-----------|---|
| 1 | CHG'D DOG OD /RH/PD/ | 5-81 | J. QUIRK | * |
| 2 | ADDED 'M' MODIFICATION SPEC. AND CONCENTRICITY INDICATION /RJ/JLQ/ | 3-83 | J. QUIRK | * |
| 3 | DEL 'M' MODIFICATION SPEC. & NOTE 1. ADDED P/N. TOL ON A WAS +0.015 -0.000". REV CODE REF FROM Y14.5 TO B18.2.1. /PD/PM/ | 1-31-91 | P. MAK | * |
| 4 | ADDED IMPORTANT NOTE /MRK/PD/ | 7-17-91 | P. MAK | * |
| 5 | CHG'D FROM HEX CAP SCREW. ADDED NOTE FOR SUBSTITUTION. /PD/ | 09/18/96 | J.C.LIGHT | |
| 6 | REDRAWN ACAD JLM | 8/24/09 | E.L.WELLS | |

© 2009 BABCOCK & WILCOX POWER GENERATION GROUP, INC. ALL RIGHTS RESERVED.
 THIS DRAWING IS THE PROPERTY OF BABCOCK & WILCOX POWER GENERATION GROUP, INC. AND CONTAINS CONFIDENTIAL AND PROPRIETARY INFORMATION OWNED BY BABCOCK & WILCOX POWER GENERATION GROUP, INC. ANY COPYING, USE, OR DISCLOSURE OF THIS DRAWING WITHOUT THE WRITTEN PERMISSION OF BABCOCK & WILCOX POWER GENERATION GROUP, INC. IS STRICTLY PROHIBITED.
 THIS MATERIAL IS PROTECTED UNDER TRADE SECRET AND UNFAIR COMPETITION LAWS AND THE EXPRESSION OF THE INFORMATION CONTAINED THEREIN IS PROTECTED UNDER FEDERAL COPYRIGHT LAWS.
 "DO NOT SCALE - USE DIMENSIONS ONLY"

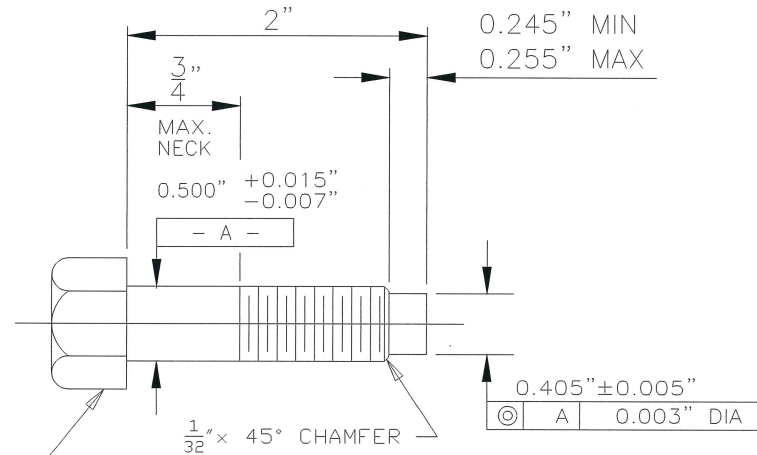

HVY HEX BOLT $\frac{1}{2}$ " DIA x 2" LG 13UNC2A A307B
 NOTE: REG HEX HEAD BOLT OR CAP SCREW WITH REG HEX OR HVY HEX HEADS MAY BE SUBSTITUTED.

MK 3128

B&W P/N 3014167

BOLT OR CAP SCREW TO BE PER ANSI-B18.2.1, EXCEPT AS SHOWN.

IMPORTANT NOTE:

AFTER MACHINING - CLEAN UP THREADS AND TRIAL FIT NUT.

| | | | | | |
|------------|----|--------------------|--------|---|--------------|
| PROJECT NO | | USER DEFINED FIELD | | "PROPRIETARY AND CONFIDENTIAL INFORMATION" | |
| | | 01U5000-02A400 | | | |
| Dist.Cust. | NO | DWN BY | R.C.H | COA | TYPE |
| Dist.Erec. | NO | CHKD BY | P.D.-1 | SCALE | STANDARD |
| Dist.Mfg. | NO | APPVD BY | J/L/Q. | 1:1 | DATE |
| | | | | DWG NO. | 154856A A 06 |

DETAIL
 1/2" HEX BOLT
 WITH SPECIAL FULL DOG END

Detail (03/03/09)