

Rev.	Date	Revised by	C/N	Description of changes
A~01	13-Jan-16	Stefan Nilsson	10457	Drawing released.

PRE-RELEASE

DESIGN ENGR/Date: _____

MFG/SQ ENGR/Date: _____

QUALITY/Date: _____

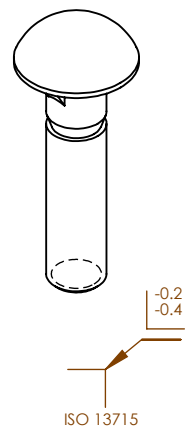
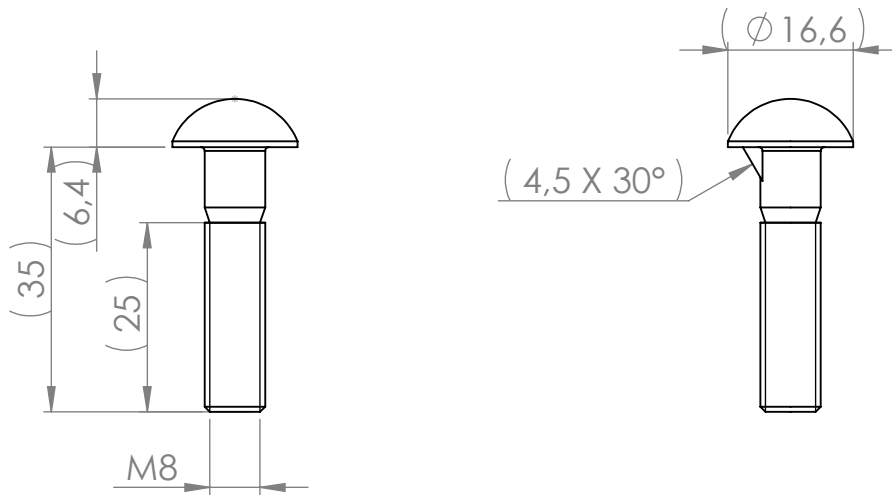
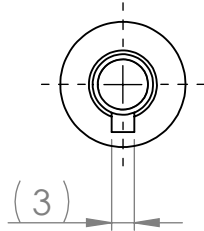

NOTES:

1) VIEWS AND DIMENSIONS FOR REFERENCE ONLY.
SPECIFICATIONS ACC TO PART DESCRIPTION.

White color.
Corrosion resistance acc to ISO9227-NSS:
minimum 12h without white rust, 36h without red rust

MATERIAL : See standard		VOLUME (mm3): 2614.69		MAT. STANDARD:	MAT.FAMILY: Steel	= REVISION LOCATION = CRITICAL QUALITY ATTRIBUTE = KEY CHARACTERISTIC
MASS (kg): 0.02		TOLERANCES SPEC:		FINISH:		
DENSITY (kg/m3): 7800		TOXICITY: REACH regulation and RoHS directive		BIOCOMPATIBILITY:		@INVACARE CORP. ALL RIGHTS RESERVED UNITS ARE MILLIMETERS UNLESS OTHERWISE SPECIFIED
REVISION STATUS:		FIRE RETARDANCY:		AUTHOR: Stefan Nilsson		CREATION DATE: 30-Dec-2015
PENDING OUTCOME OF PRE-RELEASE CHANGES (SEE REVISION TABLE ABOVE)				PART DESCRIPTION: BOLT M8x35 RND HD NIB, DIN 607, WHITE		
REVISION: A~01	C/N No: 10457	REVISED BY: SEE REVISION TABLE		FORMAT: A4	SCALE 1:1	DRAWING No / PART No 1452048
DATE: SEE REVISION TABLE				SHEET 1 OF 1		