

DIN 980 (M) - 1987 Prevailing Torque Type Hexagon Nuts with Two-piece Metal (Type M)

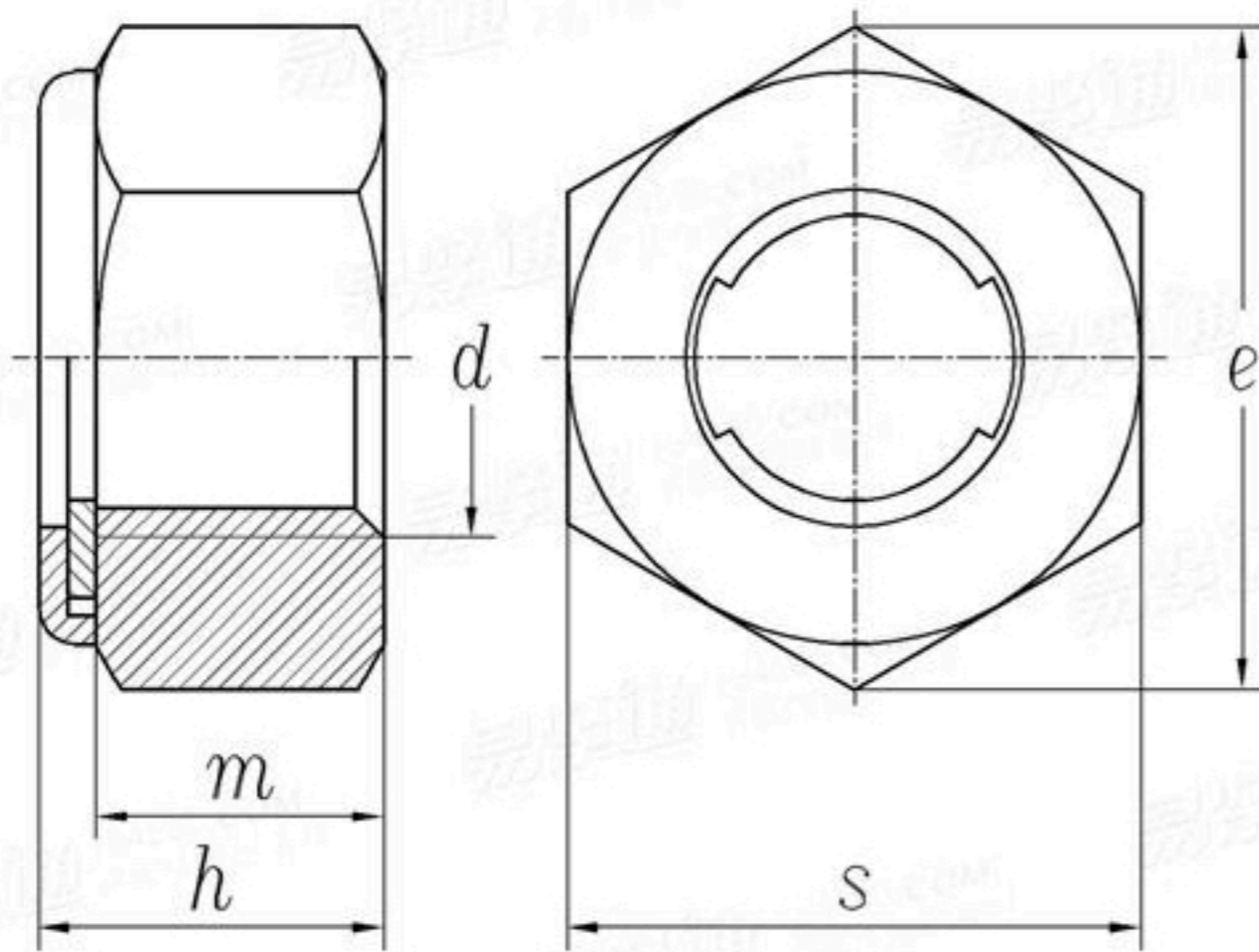

Unit: mm

Screw Thread		M3	M4	M5	M6	M7	M8	M10	M12	M14	M16
d											
P	Pitch	0.5	0.7	0.8	1	1	1.25	1.5	1.75	2	2
	Fine thread	-	-	-	-	-	1	1.25	1.5	1.5	1.5
	Fine thread	-	-	-	-	-	-	1	1.25	-	-
e	min	6.01	7.66	8.79	11.05	12.12	14.38	18.9	21.1	24.49	26.75
h	max=nominal size	3.7	4.2	5.1	6	7	8	10	12	14	16
	min	3.4	3.9	4.8	5.7	6.5	7.5	9	11	12	14
s	max=nominal size	5.5	7	8	10	11	13	17	19	22	24
	min	5.32	6.78	7.78	9.78	10.73	12.73	16.73	18.67	21.67	23.67