

VÒNG PHANH HÃM TRỤC NGOÀI

Unstressed

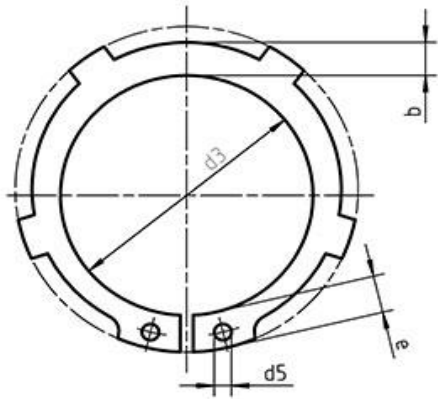

Expanded

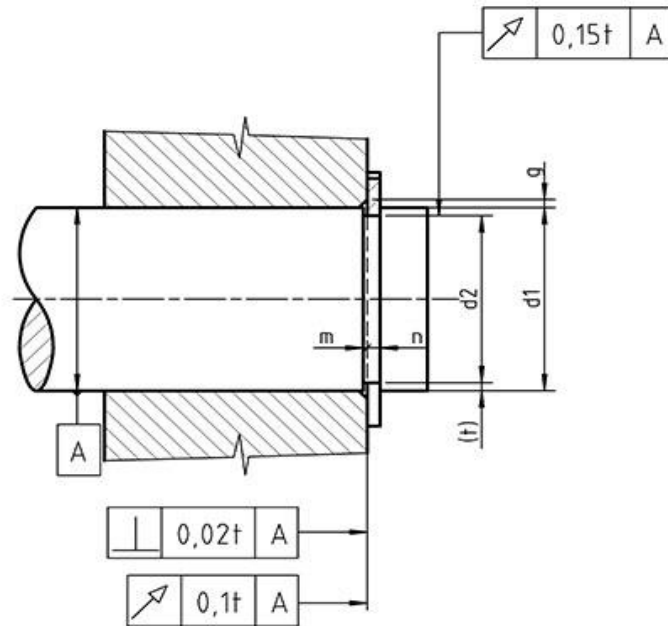
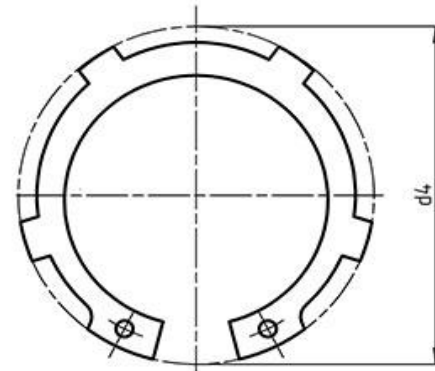

Note:**a** - height foot ring**d5** - diameter holes for ring opening**s** - thickness of the ring**b** - body Height**d3** - inner diameter of Collars**Steel:** steel**Dimensions (mm)**

Shaft diameter, d1	Circlip							Groove				Design criteria							
	s	d3		a	b	d5	Mass of 1000 units, in kg	d2	m	t	n	d4	FN	FR	g	Fhg	nabl	Nominal size of pliers as in DIN 5254	
Nominal size	Lim . Dex .	lim.de v.	max .	approx .	min .	approx .	lim.dev .	H13	min .	kN	kN	kN	min-1						
22	1,2	20,5	+0,13 -0,42	4	2,8	2	1,77	21	0 -0,13	1,3	0,5	1,5	30,4	5,65	16,9	1,5	3,8	25700	19