

PIPE SUPPORTS: GENERAL

1. STAINLESS STEEL HEXAGONAL HEADED NUTS AND BOLTS SHALL BE USED FOR ALL PIPING ON DECK AND INSIDE TANKS.
2. GALVANIZED STEEL HEXAGONAL HEADED NUTS AND BOLTS MAY BE USED FOR OTHER SYSTEMS.
3. ALUMINUM GRADE 6082-T6 SUPPORT ANGLE BARS SHALL BE USED FOR ALL PIPING SYSTEMS.
4. FOR CARBONS STEEL, ALUMINUM OR COPPER NICKEL PIPE SUPPORTS U-BOLT WITH 2MM TEFLON (PTFE) WRAP SHEET SHALL BE INSERTED TO PREVENT DIRECT CONTACT BETWEEN DISSIMILAR METALS (BETWEEN U-BOLT, PIPE AND ANGLE BAR).
5. ALTERNATIVELY ONLY FOR COPPER NICKEL PIPE SUPPORTS PLASTIC COATED U-BOLT WITH 10MM SUITABLE INSULATOR SHEET SHALL BE INSERTED TO PREVENT DIRECT CONTACT BETWEEN DISSIMILAR METALS (BETWEEN ANGLE BAR AND COPPER NICKEL PIPE).

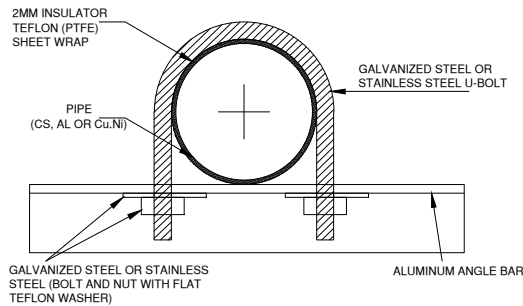

TYPICAL ALUMINUM, CARBON STEEL & COPPER NICKEL PIPE SUPPORT ARRANGEMENT

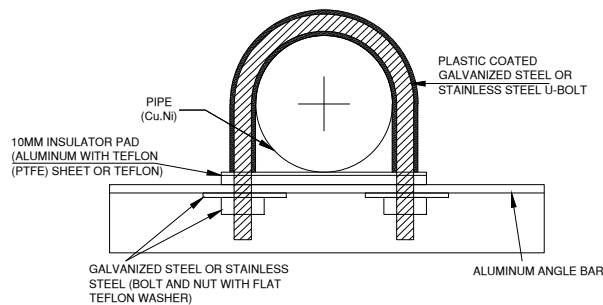

ALTERNATIVE COPPER NICKEL PIPE SUPPORT ARRANGEMENT