

SPECIFICATION REVISIONS				
REV	ECO NO	DESCRIPTION	DATE	DRAWN BY CHECKED BY
A	0056084	RELEASED PRE-PRODUCTION	18JAN2019	MMC PSK

NOTES:  
 1. MATERIAL: STEEL  
 ALTERNATIVES MUST BE APPROVED BY CUMMINS  
 FILTRATION ENGINEERING  
 2. HOLE TO BE DRILLED SEPERATELY ON THE PART  
 3. UNLESS OTHERWISE SPECIFIED, TOLERANCES TO BE  $\pm 0.25$

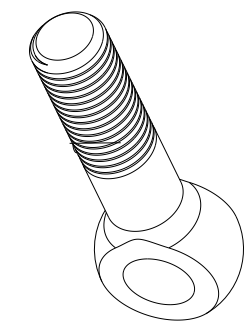

SCALE 1:1

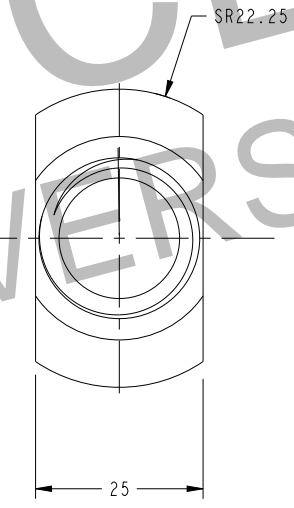
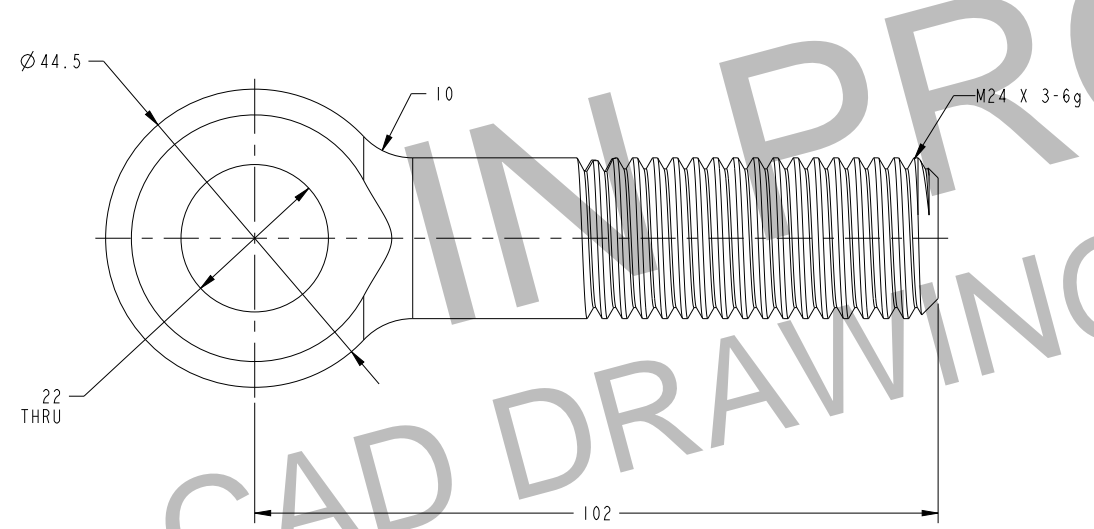
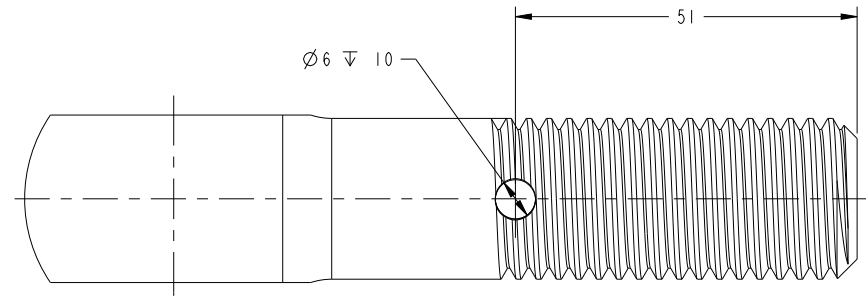

IN PROCESS  
CAD DRAWING VERSION: A.10

PART NAME A062C600		CUSTOMER Cummins Filtration	
MATERIALS REQUIRED TO COMPLY WITH ENG. STD. 10993		DESIGN MARKETING NAME	
CLASSIFICATION OF CHARACTERISTICS PER ISO 1:04		PART DESCRIPTION BOLT	
ENGINEERED P. KADAM 26DEC2018	<input checked="" type="checkbox"/> CRITICAL <input type="checkbox"/> MAJOR <input type="checkbox"/> SIGNIFICANT MINOR	UNLESS OTHERWISE SPECIFIED TOLERANCES SHALL BE AS FOLLOWS: X X.X X.XX $\angle$ NA NA NA $\pm 1^\circ$	
DRAWN 31DEC2018	THIRD ANGLE PROJECTION	CUMMINS FILTRATION RESERVES PROPRIETARY RIGHTS TO THIS SPECIFICATION AND THE DATA HEREIN THEREON AND IS FORWARDED IN CONFIDENCE. ANY DISCLOSURE OF THIS INFORMATION TO ANY OTHER PARTY WITHOUT THE EXPRESS WRITTEN CONSENT OF CUMMINS FILTRATION.	SIZE D
CHECKED P. KADAM 03JAN2019	DO NOT SCALE DRAWING UNLESS OTHERWISE SPECIFIED ALL DIMENSIONS ARE IN MILLIMETERS	SCALE 2:1	SPECIFICATION NAME 00434080
			SHEET 1 OF 1