

Automatic processing of the part requires prior consultation with
A.RAYMOND AUTOMOTIVE FASTENERS (Zhenjiang)Co., Ltd

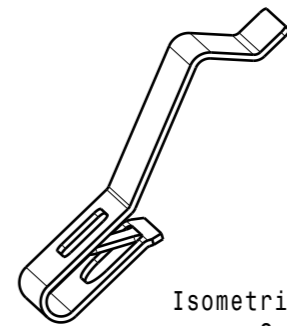

Isometric view
2:1

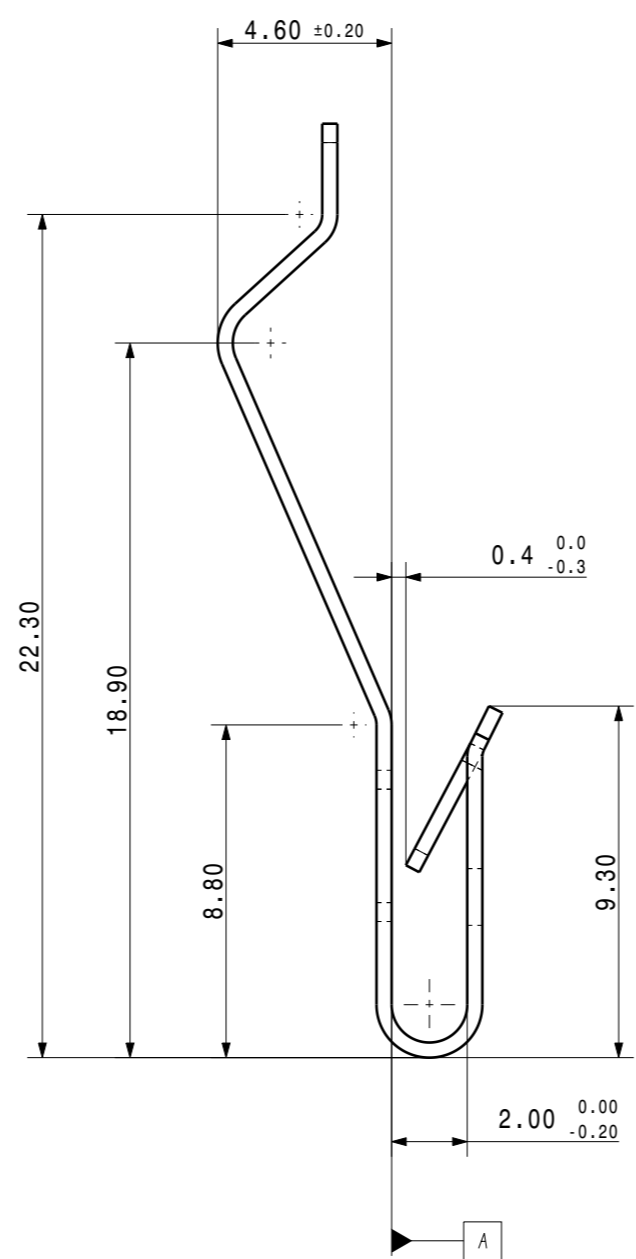
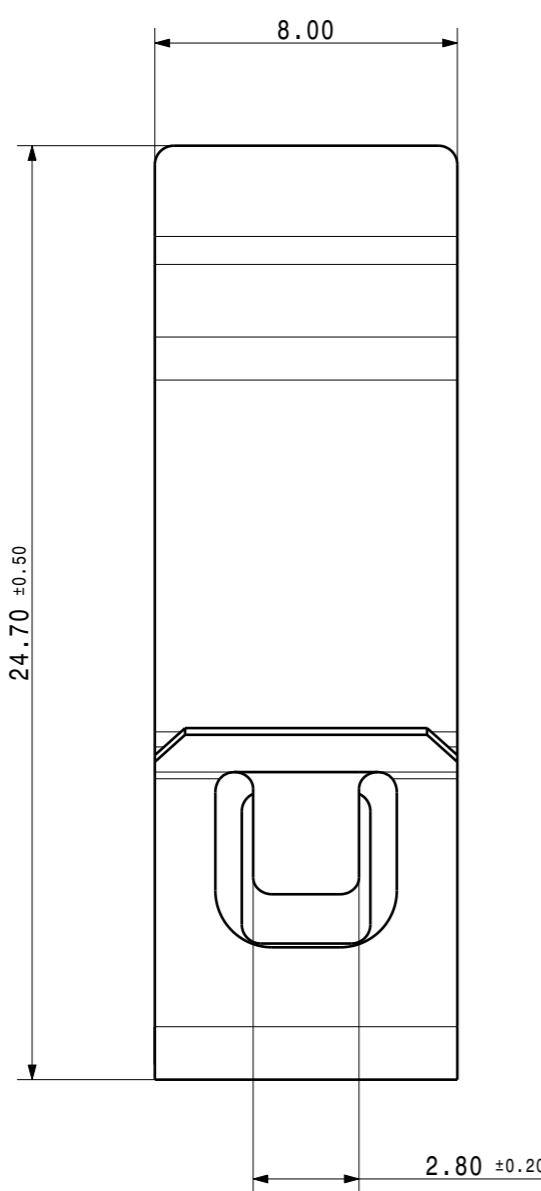
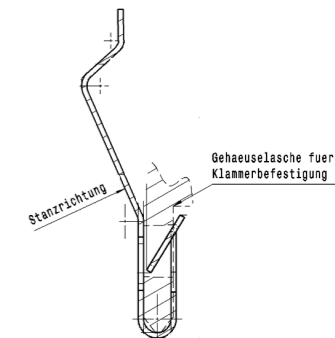

ARaymond		A.RAYMOND AUTOMOTIVE FASTENERS (Zhenjiang)Co., Ltd. 19 # Wei Si Road, Ding Mao Developing Zone, Zhenjiang 212009, Jiang Su, P.R.CHINA Phone : +86 511 8530 8888 Fax: +86 511 8889 2793	
<p>如果您在网络上有任何疑问，请联系发布者以便在使用本设计图前获取(您的语言)译本。 "CONDITIONS OF USE" This drawing and all information (the "Drawing") disclosed are the exclusive property of A.Raymond. By using this Drawing the Addressee acknowledge and accept that this Drawing (1) is covered by A.Raymond intellectual property rights or know-how and (2) is provided under the following conditions who represent a Deposit Agreement. This Drawing is for Addressee internal use only limited to its estimation. Without prior written consent of A.Raymond, no permission or rights for any purpose, is hereby granted, such as, without any limitation. (1) the copy, in part or entirely (2) and/or the presentation, in part or entirely, to any other third party outside the Addressee company or in the company but with no interest (3) and/or the distribution of the Drawings, in part or entirely, in any medium (4) and/or the creation of any derivative work. In case of breach of these conditions, Addressee shall indemnify A.Raymond from and against all damages (compensatory or consequential), costs, expenses and charges, caused or arising out of or attributable to its willful misconduct, fraud, negligence, infringement of A.Raymond Intellectual Property rights. If the Addressee does not accept these conditions, please notify A.Raymond sender immediately.</p>			
Intellectual property rights		ALL RIGHTS RESERVED	
项目号 / Project No. CN22724		Origin	
比例 / Scale 5:1		日期 / Date 11.11.2015	
Format A3		Project Manager WEI.Y	
未注公差标准 / General tolerance Dimension Angle ±0.30 ±3.00°		制作 / Prepared by WEI.Y	
视图方向		审核 / Approved 20160909012810	
ALL DIMENSIONS ARE IN MILLIMETERS		原材厚度 / Mat. thickness 0.4	
原材厚度 / Mat. thickness 0.4		体积 / Volume (mm ³) 108.1	
表面处理 / Finish		重量 / Weight (g) .8	
MKB 1.1 GZ Black -TL233 of1-t330-		表面处理代码 / Finish code ST032	
原材热处理 / Material treatment		热处理代码 / HT. code HT002	
HV5 435-535		原材代码 / Mat. code 500143566	
原材材料 / Material		零件名称 / Title	
C67S DIN EN 10132-4		Metal Clip	
零件号 / Part no. 241179 - 0 - 00		图纸类型 / Drawing type C-Customer	
客户零件号 / Customer part no.		页码 / Sheet 1/1	
CAD system & version CATIA V5 R24 SP4		文件名 / File name 241179-0C00	

Note:
- Measuring Basis is A -
* Dimension must be measured with preassembled test pin of thickness 2.0 mm

Ab	-	Change the ST018 to ST032	09.09.16	YWE
Rev.	Quant.	Indice / revision description	Date	Name

BEWARE SCALE AFTER COPY

4
3
2
1

4
3
2
1

H G F E D C B A