

TOOL & INSPECTION REQUIREMENTS:
 1. EVERY TOOL SHOULD HAVE A UNIQUE NUMBER. 2. EVERY CAVITY OF THE TOOL TO BE MARKED. 3. LAYOUT INSPECTION REPORT OF THE PART SHOULD CARRY TOOL NUMBER & INSPECTION SHOULD BE DONE FOR EACH CAVITY PART.
 4. SUPPLIER TO PERFORM & PROVIDE LAYOUT INSPECTION REPORT OF PART IN FOLLOWING CONDITIONS
 A. WHEN NEW TOOL IS MANUFACTURED FOR EXISTING PARTS. B. WHEN EXISTING TOOL IS REPAIRED / MODIFIED.
 C. WHEN PART / PARTS OF THE TOOL ARE REPLACED. D. AFTER TOOL COMPLETES THE PRODUCTION OF 1/4, 1/2, 3/4 th QUANTITY OF THE TOTAL PRODUCTION IT IS MEANT FOR.

THIS DRAWING IS A SOLE PROPERTY OF FLASH ELECTRONICS (I) PVT.LTD. & SHOULD NOT BE COPIED OR COMMUNICATED IN ANY FORMAT WITHOUT WRITTEN PERMISSION OF FLASH ELECTRONICS (I) PVT.LTD. CHAKAN.

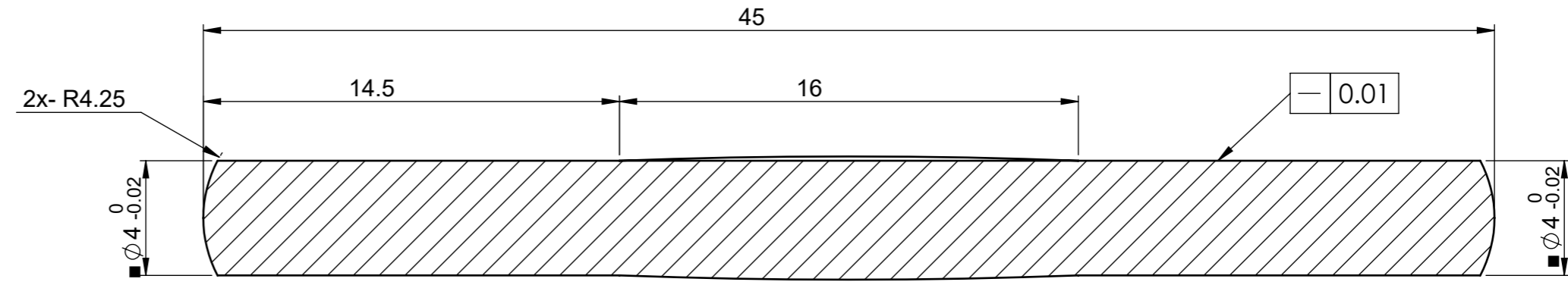

SECTION A-A

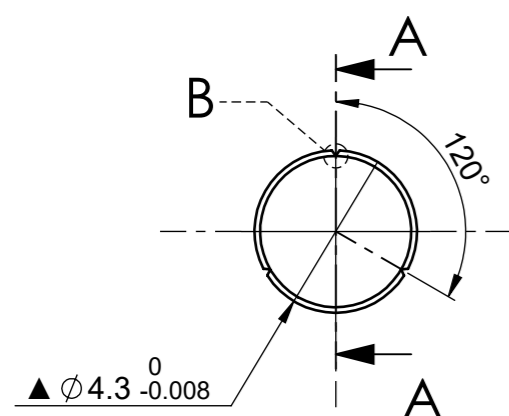
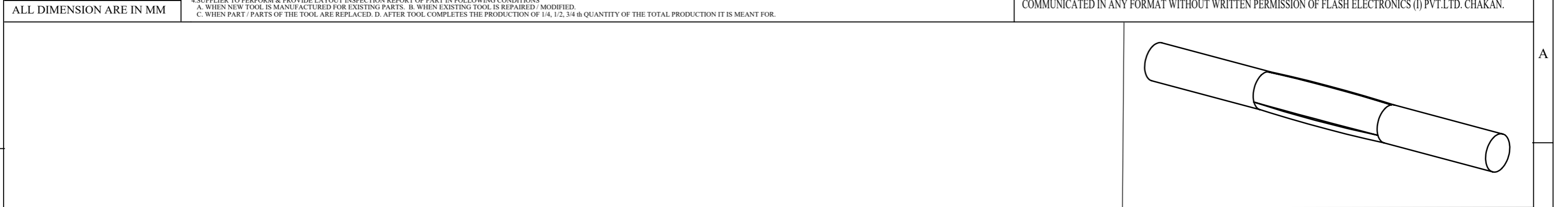
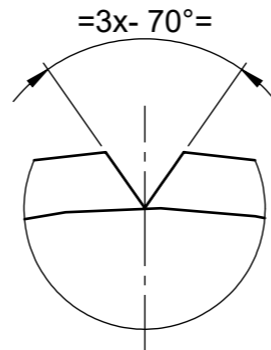

DETAIL B

- NOTE:-**
- DIMENSIONS MARKED BY '▲' ARE CRITICAL & REQUIRE SPC OR 100% INSPECTION.
 - DIMENSIONS MARKED BY '■' ARE MAJOR.
 - ALL DIMN. MARKED BY '▲' & '■' SHALL BE CONSIDERED AS PRODUCT SPECIAL CHARACTERISTICS & TO BE INCLUDED IN INWARD INSPECTION PLAN & IPAR DOCUMENTS.
 - ALL OTHER DIMENSIONS ARE MINOR.
 - PART SHOULD BE FULLY COMPLIANT WITH EU REGULATION (EC) NO. 1907/2006 (REACH) & ALL APPLICABLE, RELATED LEGISLATION.
 - PART SHOULD BE FULLY COMPLIANT WITH INDIAN REGULATION QUALITY CONTROL ORDER 2020, AS PER FLASH STANDARD - FLASH 00 012.
 - REFER 3D MODEL FOR MISSING DIMENSIONS.
 - PART SHOULD BE FREE FROM BURR & SHARP EDGES.

ONLY FOR COSTING PURPOSE

ECN NO.		REV.		REVISION DESCRIPTION			DRN	CHD	APPD.	DATE	MATERIAL: ■ ISO 8742-4x45-A1		SURFACE FINISH		TITLE: GROOVED PIN			
											TREATMENT: ■ 550~650 HV30		DRAWN: SANTOSH		DATE: 20.08.2024		DRG NO.: SK22499-00-00	
											WEIGHT(g): 4.58g		CHECKED:				REV. NO: 00	
													APPROVED:				SHEET: A3	
													SCALE: 5:1		SHEET: 1 OF 1		MODEL: KBx	
													PROJ.:				FLASH ELECTRONICS (INDIA) PVT.LTD. A-4, M.I.D.C. Chakan, Pune- 410 501. Tel.: 91-2135-666000 Fax: 91-2135-666109 Email : flash@flashgroup.in	
1																	REV.NO/DATE:-03 / 06-07-2020	